



TRACEY CONCRETE

Agricultural Brochure

DESIGNING | MANUFACTURING | DELIVERING



traceyconcrete.com

Tracey Concrete is one of the largest precast concrete manufacturers in the UK and Ireland.

Tracey Concrete's success has been built on the consistent quality of our products, efficient delivery and outstanding customer service. With our vast experience and expertise in the construction industry, we have been able to design and supply precast concrete products for some of the biggest projects in the UK and Ireland.

Our products comply with all necessary certifications and are accredited with the most up to date Irish, UK and European standards, with the relevant products being BSI kitemarked and CE marked.

WE SPECIALISE IN

- Precast Concrete Drainage Systems
- Precast Tunnelling Systems
- Agricultural Precast
- Cable Trough Systems
- Ready-mix and Liquid Screed Concrete
- Bespoke Precast Concrete Systems
- Bio Klenze™ Sewage Treatment Systems
- Quarry Products



Our Story

Tracey's began as a family-run contracting business in the early 1960's installing water-mains throughout Northern Ireland. In the 1970's, Tracey Concrete Ltd was formed as a readymix concrete supplier to the public.

Over the years, the company expanded into new product ranges manufacturing precast concrete cills & lintels and agricultural cattle slats. In the 1980's, the business expanded into precast drainage product's manufacturing concrete pipes and manhole rings becoming a leading precast drainage supplier in Ireland.

In 2003, Tracey Concrete entered the UK market supplying projects in England, Scotland and Wales. Tracey Concrete are now a leading supplier of Precast Concrete throughout the UK and Ireland.



Tracey Readymix Lorry 1970's



Tracey Concrete's Precast Factory - Enniskillen



Tracey Concrete's Belcoo Quarry



Contents

| | |
|--|----|
| Introduction | 2 |
| Our Story | 3 |
| Cattle Slats | 6 |
| Safety Manhole Slats & Slabs | 7 |
| Cubicle Beds & End Walls | 8 |
| Multi Purpose - Pig & Sheep Slats | 10 |
| Support Beams, Columns & Passage Slabs | 11 |
| Cattle Drinkers | 12 |
| Slurry Channel | 13 |
| Refits | 15 |
| Readymix Concrete | 16 |
| Concrete Pump | 17 |
| Agri Lime | 18 |
| Drawings, Tank Layout and Other Precast Products | 19 |



CATTLE SLATS



Tracey Concrete Ltd has been supplying cattle gang slats and other precast products to the farming industry in the UK and Ireland for over 40 years. We supply a full range of cattle gang slats. All cattle slats are manufactured and CE Marked by BSI to the requirements of BS EN 12737:2004 A1:2007 and BS EN 13369:2013.

Our cattle slats are designed to provide maximum comfort and cleanliness. They are manufactured with a profiled design, to allow for quick release of slurry into the tank, with a durable, smooth and non-slip surface.

| Width (mm) | Depth (mm) | Slot Width (mm) | Lengths Available (mm) | Lengths Available (feet) |
|------------|------------|-----------------|--|--|
| 1140 | 178 | 38 | 2140, 2290, 2440, 2590, 2745, 2895 | 7', 7'6", 8', 8'6", 9', 9'6" |
| 1200 | 178 | 38 | 3050, 3200, 3355, 3505, 3650, 3800, 3950, 4100 | 10', 10'6", 11', 11'6", 12', 12'6", 13', 13'6" |
| 1200 | 220 | 38 | 4275, 4420, 4570, 4875, 5035 | 14', 14'6", 15', 16', 16'6" |

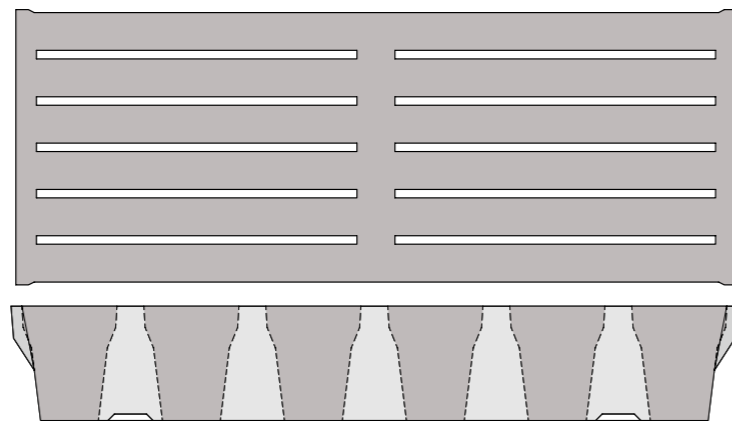

Imposed loading BS5502

New slat profile for cleaner slat



SAFETY MANHOLE SLATS & SLABS

Safety manhole slats and slabs allow for easy, yet safe, access to the slurry tank to allow for the agitation and spreading of slurry. Our mixing points are compatible with all types of mixing / pumping systems. Safety slats are made using the same profiles as our gang slats, thus allowing for the fitting of them at a later stage if required.

Safety manhole slats and slabs can be manufactured in the middle of the slat or offset to the side for easier access for mixing, depending on the tank access.

| Type | Width (mm) | Depth (mm) | Slot Width (mm) | Lengths Available (mm) | Lengths Available (feet) |
|----------------|------------|------------|-----------------|---|---|
| Slatted | 1200 | 178 | 38 | 2140, 2290, 2440, 2590, 2745, 2895 3050, 3200, 3355, 3505, 3650, 3800, 3950, 4100 | 7', 7'6", 8', 8'6", 9', 9'6" 10', 10'6", 11', 11'6", 12', 12'6", 13', 13'6" |
| Solid / Offset | 1100 | 178 | - | 2140, 2290, 2440, 2590, 2745, 2895 3050, 3200, 3355, 3505, 3650, 3800, 3950 | 7', 7'6", 8', 8'6", 9', 9'6" 10', 10'6", 11', 11'6", 12', 12'6", 13' |
| Slatted | 1200 | 220 | 38 | 4250, 4400, 4570, 4800, 5000 | 14', 14'6", 15', 16', 16'6" |
| Solid | 1320 | 178 | - | 2140, 2290, 2440, 2590, 2745, 2895 3050, 3200, 3355, 3505, 3650, 3800, 3950, 4100 | 7', 7'6", 8', 8'6", 9', 9'6" 10', 10'6", 11', 11'6", 12', 12'6", 13', 13'6" |
| Solid | 1200 | 220 | - | 4250, 4400, 4570, 4800, 5000 | 14', 14'6", 15', 16', 16'6" |

- Allows for easy, yet safe, access to the slurry tank to allow for the agitation and spreading of slurry.
- All mixing points come with a galvanised safety grill, concrete inserts or galvanised steel cover.



Concrete inserts and safety grill



Galvanised steel safety lid & grill



CUBICLE BEDS & END WALLS

Tracey Concrete manufacture concrete cubicle beds to suit practically any cattle housing situation. From calves to adult cows, in single runs or head to head, on existing floors as a relocatable unit or as part of a precast suspended system. Our beds are designed to ensure optimum livestock comfort. Mats to suit our cubicles are available from all mat suppliers in the UK & Ireland.

Single Cow Cubicles & End Walls - Dimensions

| Width (mm) | Depth (mm) | Gradient (mm) | Lengths Available (mm) | End Walls (feet) |
|------------|------------|---------------|-------------------------------------|------------------|
| 1140 | 225 - 178 | 47 | 1950, 2100, 2250, 2400, 2550, 2700. | 7'0" - 9'0" |



Single cubicle beds

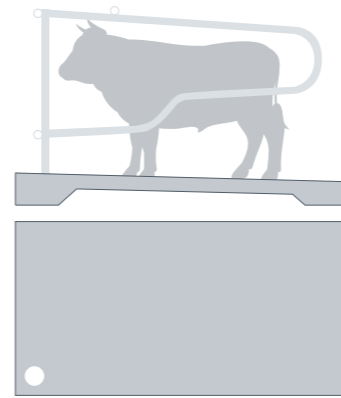

Double Cow Cubicles & End Walls - Dimensions

| Width (mm) | Depth (mm) | Gradient (mm) | Lengths Available (mm) | End Walls (feet) |
|------------|------------|---------------|------------------------|------------------|
| 1140 | 280 - 200 | 80 | 4250, 4570, 4875 | 14'0" - 16'0" |



Cubicle end wall

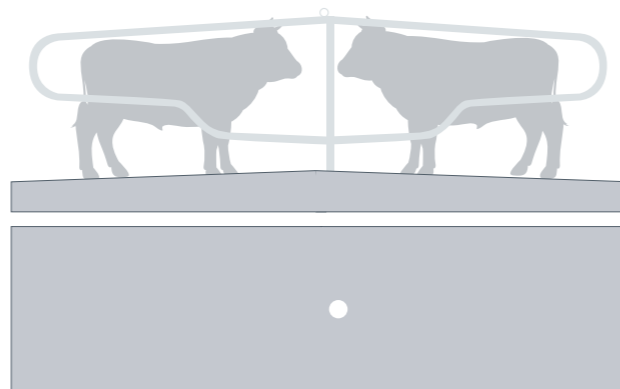

- Sizes manufactured to suit cattle at all stages from young calves to the largest cows
- Suitable for use in existing houses or new build houses
- Designed to ensure optimum livestock comfort



MULTI PURPOSE PIG & SHEEP SLATS



Tracey Concrete offer the full range of Multi Purpose Pig and Sheep slats. Tailored to suit new build or replacement projects, our Pig and Sheep Slats are manufactured in our modern factory using a dry cast mix resulting in high concrete strengths and a highly durable finished product. The Tracey slat has a high quality finish and a particular design profile which gives a non-slip finish and results in greater animal comfort.

| Width (mm) | Depth (mm) | Slot Width (mm) | Lengths Available (mm) | Lengths Available (Feet) |
|------------|------------|------------------|---|---|
| 1152 | 150 | 18 | 1061, 1213, 1361, 1513, 1666, 1818, 1971, 2123, 2275, 2428, | 3'6", 4', 4'6", 5', 5'6", 6', 6'6", 7', 7'6", 8', 8'6", 9', 9'6", 10', 10'6", 11', 11'6", 12', 12'6", 13' |
| | | Multi Purpose 20 | 2580, 2733, 2885, 3050, 3200, 3350, 3500, 3650, 3800, 3950 | |

- Full Range of sizes from 1.061m to 3.95m long (3 1/2' to 13')
- High Strength for great durability
- Brushed Finish – reduced slip surface
- Manufactured with dry-mix concrete for added strength
- Manufactured to IS EN 12737

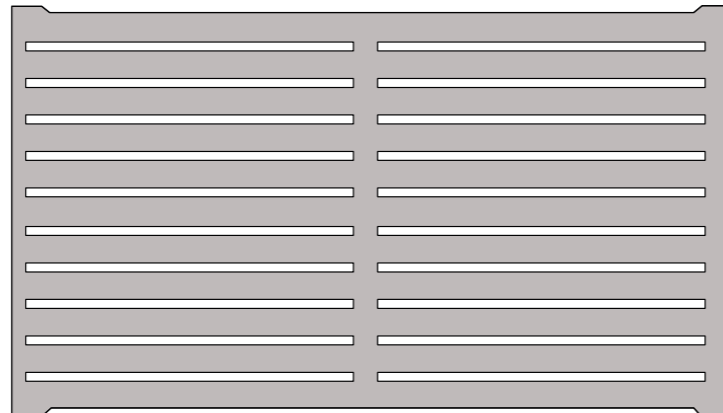

SUPPORT BEAMS

Support Beams are manufactured in lengths from 2100mm – 4250mm with a loading capacity of 6T as standard.

- Support beams are manufactured with loading capacity of 6 tonne as standard
- Beams with an increased loading capacity can be manufactured to meet customer requirements

| | | |
|----------------------|----|-----------------------------------|
| Standard Size | mm | 300 x 300 |
| Special Sizes | mm | 215 x 300 500 x 300 215 x 150 |



COLUMNS - PRECAST PIPES



Precast pipes used as columns for support beams for slatted tanks. They offer a swift solution compared to the time-consuming process of pouring traditional columns, thereby expediting construction timelines.

Furthermore, their ample availability in substantial stock levels ensures ready access, minimising delays and streamlining project progression

- Sizes of pipes for columns range from 300 - 600
- Installation is swift and efficient

PASSAGE SLABS

- Long spans
- Quick installation, particularly when compared to wet concrete solutions
- Immediate working platform
- High load capacity
- Preformed holes for services
- Available in 150mm, 200mm & 250mm



CATTLE DRINKERS



Due to the weight of the concrete water drinkers, less time is required to fit and install them as they are able to sit under their own weight.

Unlike plastic drinkers, the robustness of the precast water trough removes the risk of the trough losing shape or being pushed around by livestock.

- Durable – maintains shape in all conditions and centre core pipe is protected from frost etc.
- Versatile – can be easily moved to a different location using the correct lifting equipment

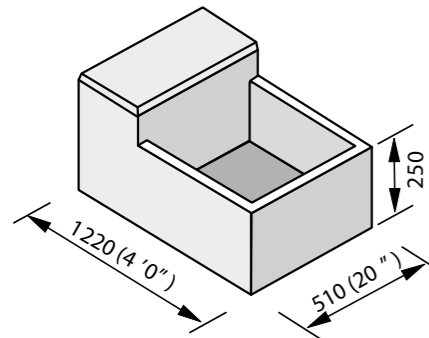

Approx.
15 Gallon
68 Litre

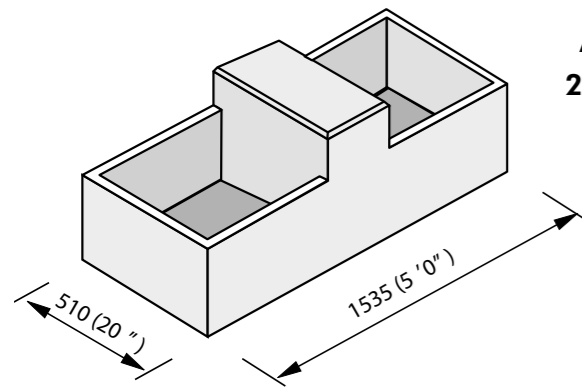

Approx.
25 Gallon
90 Litre

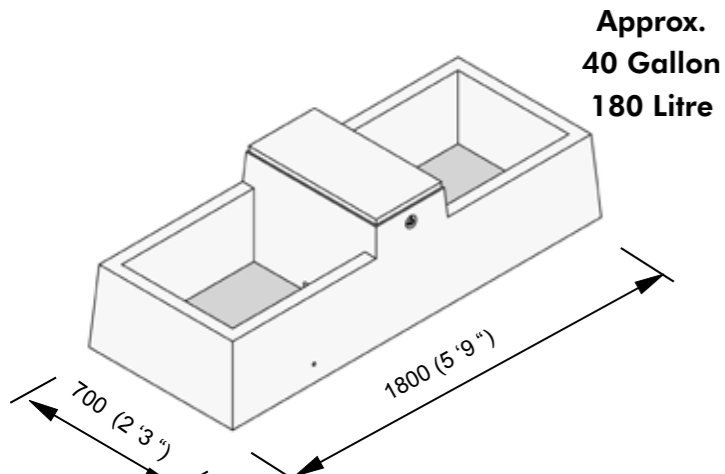

Approx.
40 Gallon
180 Litre



| Product | Parallel Section | Overall Height | Weight | Code |
|----------------|------------------|----------------|--------|----------|
| - | mm | mm | KG | |
| Single Drinker | 1220 x 510 | 250 | 272 | WSDR1200 |
| Double Drinker | 1535 x 510 | 250 | 340 | WSDR1500 |
| 40 Gal Drinker | 1800 x 700 | 350 | 540 | WSRD0040 |
| Drinker Lid | | | | DRIL0915 |



SLURRY CHANNEL UNITS

Slurry Channel Units are meticulously designed to facilitate slurry flow to and between storage tanks. By leveraging gravity, our channels ensure smooth slurry movement, reducing the need for mechanical scraping systems. This design innovation also eliminates the requirement for slurry agitation within the shed, optimising operations and efficiency.

Diagonal Slats feature a greater gap-to-solid surface ratio, enabling versatile scraper usage in both vertical and horizontal orientations. The slats' angled gap directs slurry flow smoothly into the channel below, facilitating efficient movement.

| Type | Width (mm) | Depth (mm) | Lengths Available (mm) | Slot Width (mm) |
|----------------|------------|------------|------------------------|-----------------|
| Slurry Channel | 1000 | 1200 | 2000 | - |
| Diagonal Slat | 1320 | 178 | 2000 | 38 |

- Diagonal Slats are available in three variants: Cattle Bearing (2.5 ton Axle Loading), Tractor Bearing (4.5 ton Axle Loading), and Heavy Duty (8.5 ton Axle Loading).
- Diagonal slats are optimally suited for use with a scraper system.

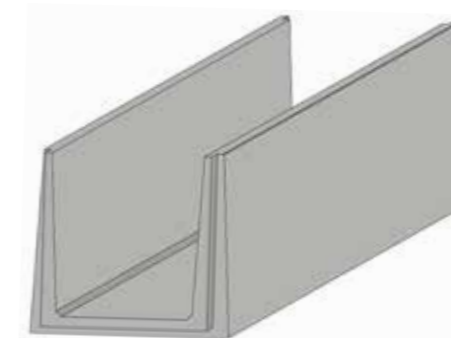

Slurry Channel



Diagonal Slat





Tracey Concrete offers a refit service of replacing failing single slats on existing tanks with 6 rib gang slats. If you have any tanks that require this service please contact our sales team to call and price the project.

Every year livestock are killed or injured due to the failure of old or deficient slats. Under current regulations slats have a design life of 20 years, but their lifespan can vary greatly depending on use, load and manufacturer.

Deep or wide cracks allow the sulphates from the slurry to attack the slat and corrode the steel inside causing failure. Farmers must check their slats every year to ensure their own safety and that of their cattle.

- The ideal time to check your slats is when the cattle have been turned out.
- Slats should be washed down so cracked & damaged slats can be identified.
- If slurry has been allowed to build up to the underside of slats their lifespan will be significantly reduced as both the concrete and reinforcing steel will have corroded.
- When in doubt replace slats.



Corroded slat: strength is weakened and high risk of failure



Refit before & after



CONCRETE PUMP & READYMIX



Tracey Concrete can offer services of a 34X concrete pump anywhere in Ireland. The concrete pump has a 34m four-section placing boom with roll-n-fold system and radio remote control. It is the safe solution for concrete pours for slurry tanks, walls and silo floors as it does away with the need for skips.

We have our own fleet of readymix concrete lorries to supply any project within Fermanagh and neighbouring counties. Supplying concrete to the agricultural community for the last 40 years, we have a reputation of top-quality readymix concrete products.



CONCRETE PUMP & READYMIX

The all-around machine with a boom length that serves a wide range of construction jobs with 4-section boom versatility, fast set-up and all the time-saving features that a Schwing concrete pump can offer. With its reach, unrestrained set-up area, and high pump output, its ideal for all types of placement; ranging from small to large pours.

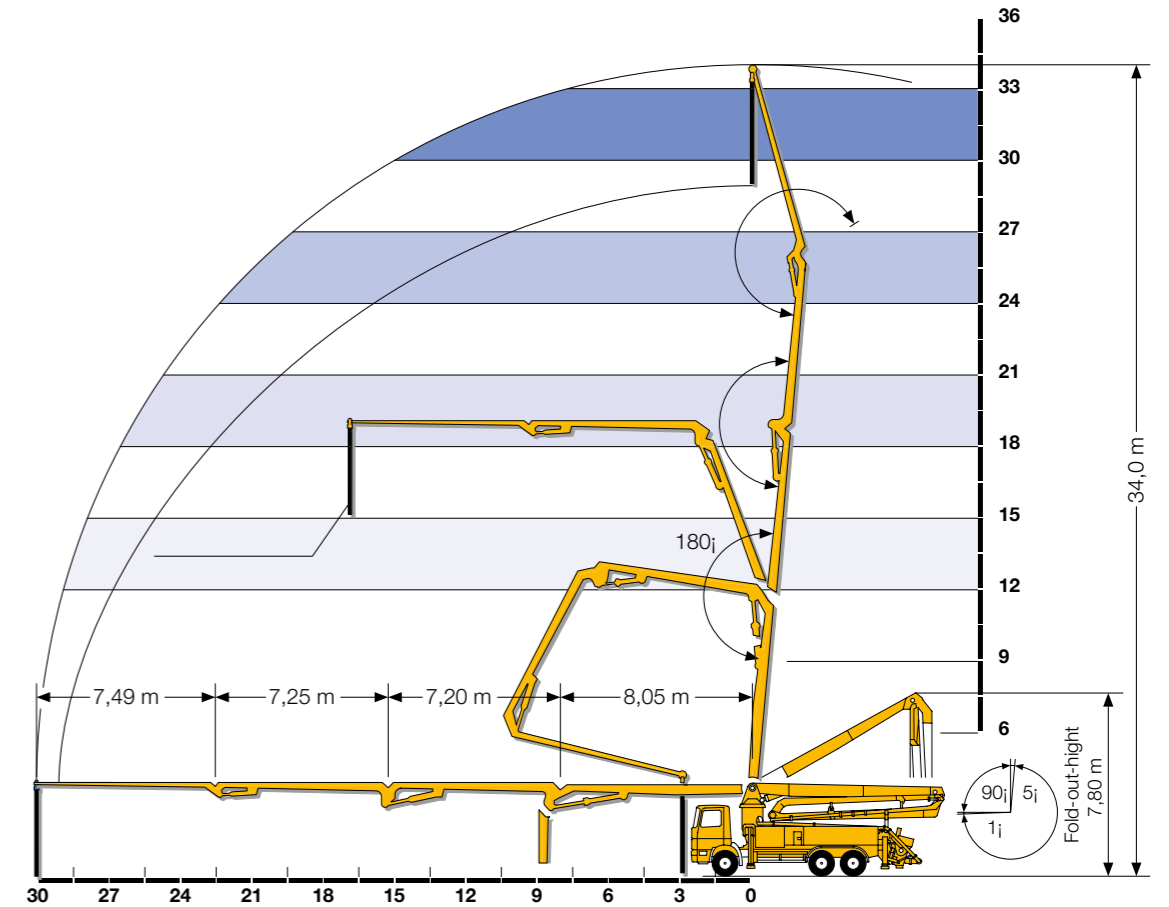

AGRI LIME

Tracey Concrete manufactures high-quality ground limestone products suitable for all soil types. As one of the select producers of Department of Agricultural-approved Lime, we provide the choice of either High Magnesium or High Calcium Lime. Our services include both collection and delivery to Fermanagh and the surrounding counties. Both types of lime boast a High Total Neutralizing Value (T.N.V.) and offer a cost-effective solution for enhancing soil conditions.

- Improves availability of essential nutrients
- Improves soil physical condition
- Reduces Al and other metal toxicities
- Stimulates microbial activity



**An Roinn Talmhaíochta,
Bia agus Mara**
Department of Agriculture,
Food and the Marine



Tipper tipping a load of Lime

DRAWINGS & TANK LAYOUT

We can supply auto-cad drawings illustrating the layout of the proposed tank for approval before installation starts. This assists the confirmation of mixing points to maximise efficiency. Our experienced sales team can visit the site to take measurements and check access for our delivery lorries.

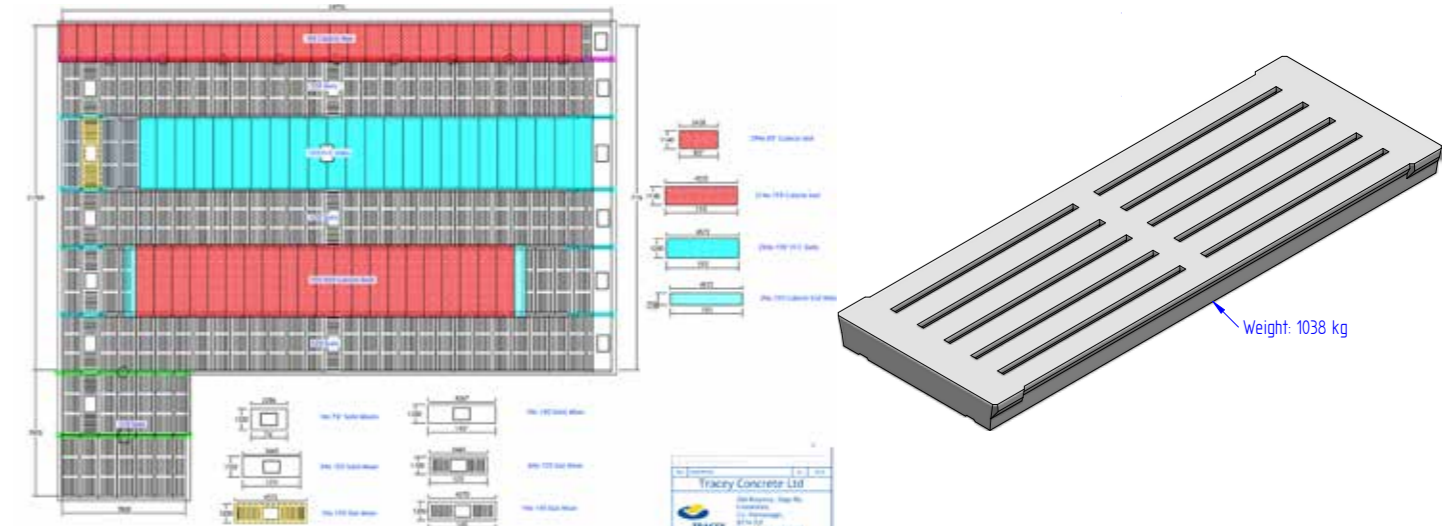

OTHER PRECAST PRODUCTS



Concrete Pipes



Gate Posts



Effluent Tanks



Manhole Rings



Interlocking Blocks



Headwalls



H Posts & Gravel Boards



Kerbs



MaxumStone Retaining Wall



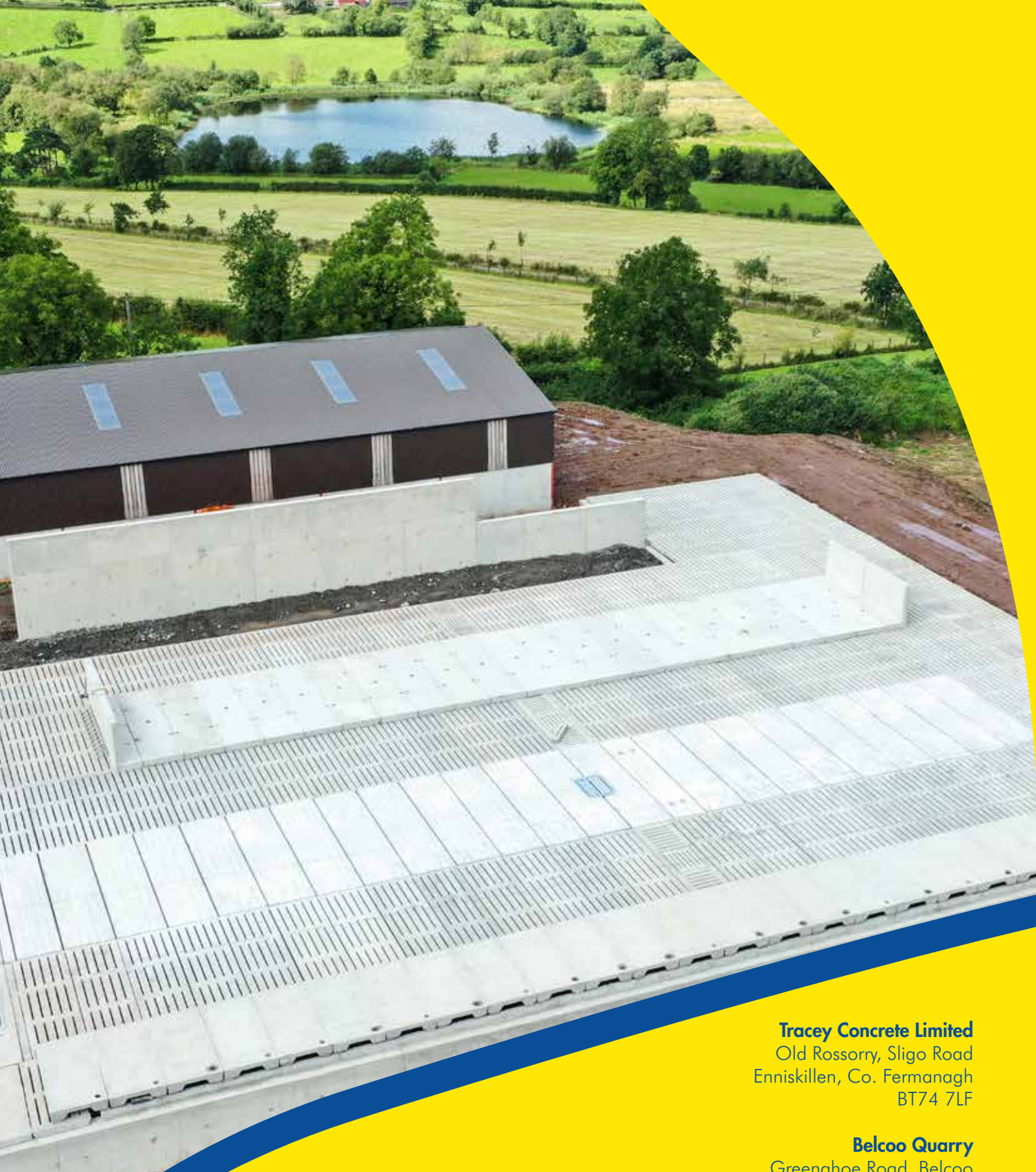

Tracey Concrete Limited
Old Rossorry, Sligo Road
Enniskillen, Co. Fermanagh
BT74 7LF

Belcoo Quarry
Greenahoe Road, Belcoo
Co. Fermanagh
BT93 5HD

TELEPHONE
028 6632 6437

EMAIL

headoffice@traceyconcrete.com
traceyconcrete.com



ISO
9001:2015
Quality
Management

ISO
14001:2015
Environmental
Management

OHSAS
18001
Occupational
Health and Safety
Management

