

FULL RANGE OF KERBS

Tracey Concrete manufactures a full range of precast Kerbs made to BS EN 1340.

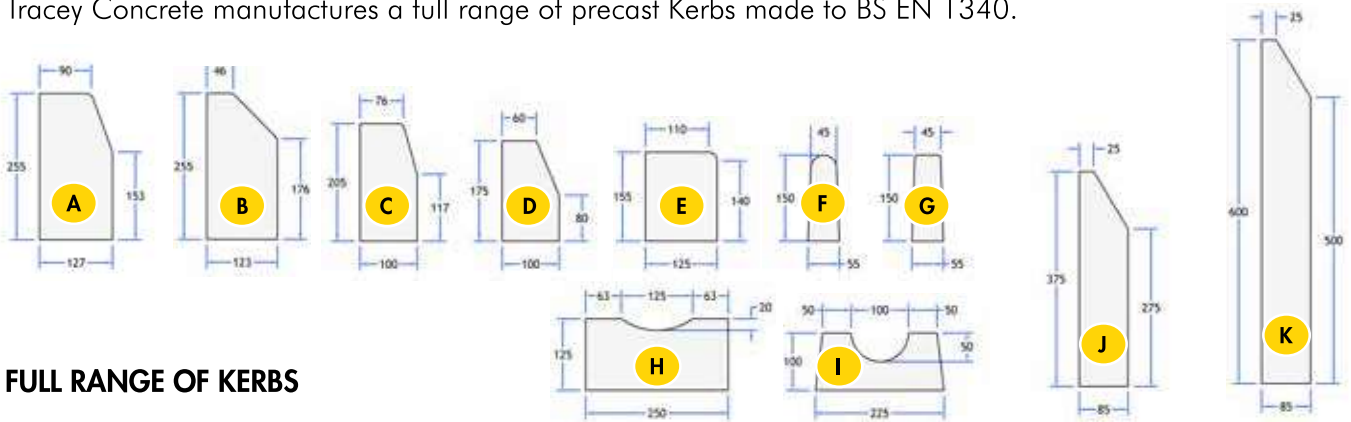

FULL RANGE OF KERBS

	Type of Kerb	Depth	Width	Length	Approx Weight	Pressed / Wetcast	Code
-	-	mm	mm	mm	KG	-	Sage
A	10 x 5 Half Battered	255	127	910	61	Pressed	KERB1005
B	10 x 5 Kerb Full Battered	255	123	910	57	Pressed	KERF1005
C	8 x 4	205	100	910	39	Pressed	KERB0804
D	7 x 4	175	100	910	31	Wetcast	KERB0704
E	6 x 5 Bullnose	155	125	910	39	Pressed	KERB0605
F	6 x 2 Round Top	150	55	910	14	Wetcast	KERRO602
G	6 x 2 Flat Top	150	55	910	15	Wetcast	KERFO602
H	10 x 5 Channel	125	250	910	59	Pressed	CHAN1005
I	9 x 4 Channel	100	225	910	35	Wetcast	CHAN0904
J	Dwarf Wall	375	85	910	58	Wetcast	DWAL1503
K	Dwarf Wall Deep	600	85	910	96	Wetcast	DWAL2403
L	Solid Segment (Cheese Block)	255	305	305	43	Wetcast	DWAL1503
M	18 Radius Kerb	255	125	450	48	Wetcast	KERB0018

