

- Notes:
- All Dimensions are in millimeters.
 - Concrete;
 - Grade: C45/55
 - Exposure Class: DC3
XC3/4
XF4
 - Reinforcement Grade: B500B
 - Cover to Reinforcement: 40mm
 - Concrete Designed to: BS EN 1992-1-1:2004
 - Approx. Weight: 325Kg
 - Handling: 3No Rd24 Threaded Lifting Sockets
Recommend: Halfen Rd 24 Lifting Loop

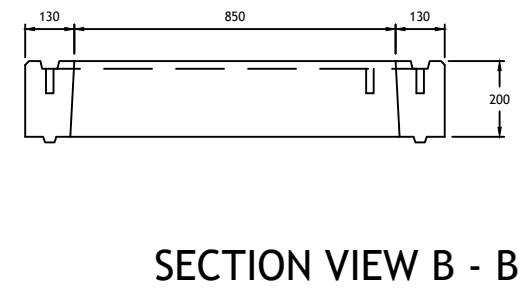
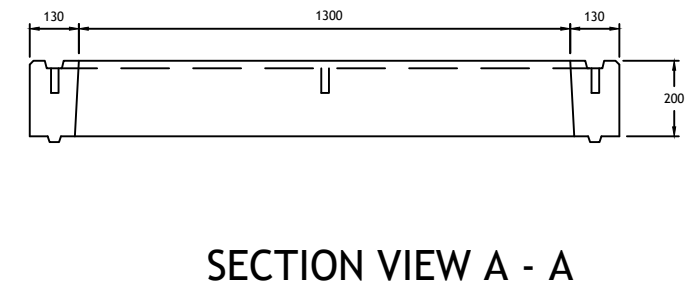
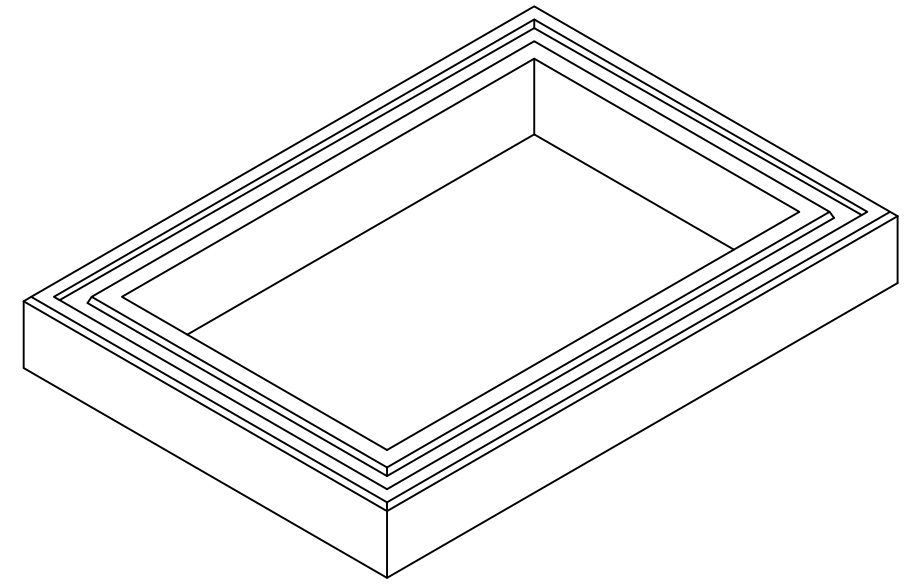
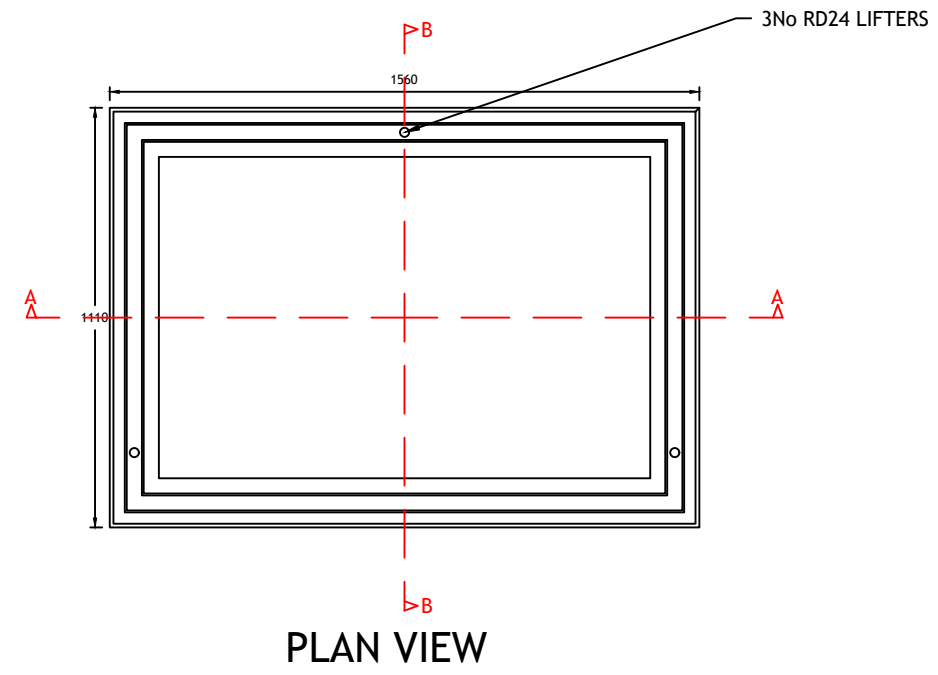

REV:	DESCRIPTION:	BY:	DATE:

Old Rossorry, Sligo Rd, Enniskillen,
Co. Fermanagh, BT74 7LF
T: +44 (0)28 6632 6437; F: +44 (0)28 6632 4908
headoffice@traceyconcrete.com

CLIENT:
Tracey Concrete Ltd

PROJECT/SITE:
Product Drawing

DRAWING TITLE:
Comms 1 Riser

JOB NO:	ORDER NO:	DRAWING STATUS:
DATE: October 2022	DRAWN BY: SM	CHECKED BY: DM
SCALE: 1:20 @ A3	REVISION:	SHEET NO: